

**MOSFi**<sup>TM</sup> 

Registered with MSME (Govt. of India)

Powered by Alaska Automation Pvt. Ltd.

An ISO 9001:2015 Company

**10** Years



**Guaranteed availability  
of Original & Genuine Parts**

## FLAP BARRIER(S.S-304) BOLT 101 (MULTI LANE)

### Features :

**MOSFi** machines are designed with the mindframe for providing quick & authorized pedestrian access control.

▶ *At time of designing and manufacturing we must take core value like security of premises, block unauthorized entry, with no noise during operation and safety of people who are using our machine.*

▶ **MOSFi BOLT SERIES** contains of FR-400 series microcontroller based motherboard which can easily integrate with any access control system (any access control system hardware/software while we provide RS485 com port. (any well-known brand).

▶ **MOSFi BOLT SERIES** machine are decorated with **ANTI CRASH SENSOR** (for safety of user), **ANTICONGULATION SENSOR** (blocking of two person entry), **ANTI PINCH FUNCTION** (support with requirements of fire fighters), **AUTO CLOSE MODE** (in prescribed time **DIRECTION CONTROL** (for pedestrian **IN/OUT**) **FLAP INDICATOR LIGHT** (For better visibility).



Designed in Italy

**100%**

Make in India

India's No.1 Manufacturer of Entrance Automation Product



Registered with MSME (Govt. of India)  
 Powered by Alaska Automation Pvt. Ltd.  
 An ISO 9001:2015 Company

# 10 Years

## Guaranteed availability of Original & Genuine Parts



### Technical Specification :

#### FLAP BARRIER(S.S-304) BOLT 101 (MULTY LANE)

Passage Width :	600 mm	Mother board :	MOSFI FR-400
MATERIAL :	S.STEEL-304 18 Guage	Anti crash sensor :	IN-BUILT
Operating time :	1.5Sec	Anti Coagulation sensor :	IN-BUILT
FLAP LED INDICATOR :	RED/GREEN/BLUE	Auto close sensor :	IN-BUILT
POLISH/FINSH :	SS BRUSH POLISH	Alarm :	Anti side access/Block passage
FLAP DIMENSION :	280mm*340mm	Access through :	S.Card+Pin+Push button
BODY DIMENSION :	900*300*880	User capacity :	1000 User
Opening direction:	BIDIRECTIONAL	Verification Mode :	3 Mode,No Data
DRIVE VOLTAGE :	DC 24-V	IP PROTECTION :	IP43
POWER :	AC 220-V 50/60HZ	Working Humidity :	20% To 60%
Power consumption :	80 W	Working Temp :	-5° To 55° C

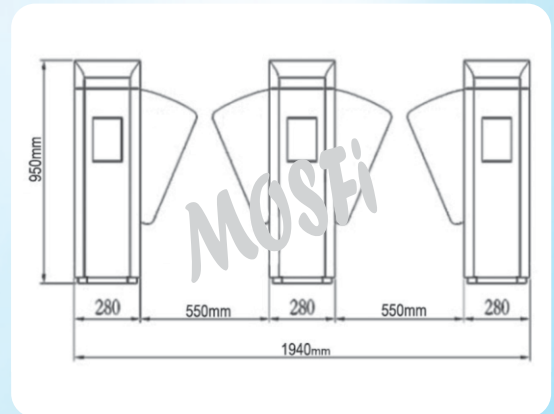
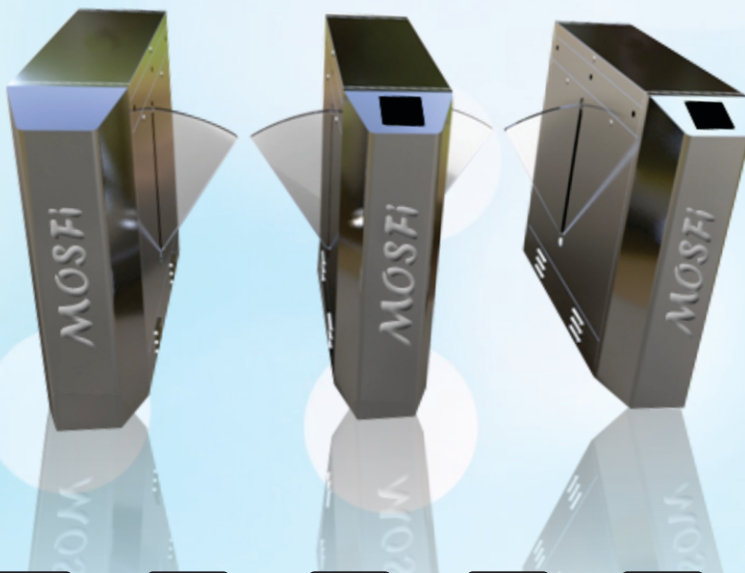

Kindly Note : AAPL Reserve the rights to make changes at any stage without any prior notice. Color & Shape may be changed from time to time.